



SEAT-511 / SEAT-515 E-Z-Go TXT RHOX 500 Series Rear Seat Kit Installation Instructions



Contents of SEAT-511 / SEAT-515 Rear Seat Kit:

- a (2 ea.) Front Seat Back Supports
- b (1 ea.) Vertical Support Bracket
- c (1 ea.) Arm Rest, Passenger Side
- d (1 ea.) Arm Rest, Driver Side
- e (1 ea.) Platform
- f (1 ea.) Footplate
- g (1 ea.) Safety Grab Bar
- h (1 ea.) Seat Bottom Handle
- i (1 ea.) Cushion Set (Not Shown)
- j (1 ea.) Bag of Hardware (Contents on Next Page)

Caution: Please read through the instructions carefully. Installer is responsible for damage if instructions are not followed properly. Look behind each drill or cut location BEFORE YOU DRILL OR CUT. Installer is responsible for damage (i.e. drilling/cutting into a wiring harness, battery, fuel tank etc.). Extra installers will be helpful in some parts of the installation. Refer to vehicle's maintenance manual for torquing specifications on reused hardware.



Contents of SEAT-511 / SEAT-515 Hardware Kit		QTY
a	3/8-16 x 1.5" Hex Head Bolts	4
b	3/8" Flat Washers	4
c	M8-1.25 x 55 Hex Head Bolts	4
d	M8-1.25 x 45 Hex Head Bolts	2
e	M8 Flat Washers	12
f	M8-1.25 Nylock Nuts	6
g	M6-1.0 x 70 Hex Head Bolts	2
h	M6-1.0 x 45 Hex Head Bolts	2
i	M6-1.0 x 35 Hex Head Bolts	2
j	M6-1.0 x 30 Hex Head Bolts	6
k	M6 Flat Washers	14
l	M6 Lock Washers	4
m	M6-1.0 Nylock Nuts	2
n	M6-1.0 Square Nuts	4
o	#10 x 3/4" Flat Head Sheet Metal Screws	2
p	5/16" Ø, 2-5/8" Useable Length Clevis Pins	4
q	Hairpin Cotter Pins (3/32" wire Ø, 1-3/4" OAL)	4
r	Weather Seal for Seat Bottom Cushion (not shown)	1

Tools Needed For Installation

- Sockets and Open Ended Wrenches: 10mm, 12mm, 7/16", 1/2", 9/16"
- Phillips Screwdriver
- Rubber Mallet (Optional)

Installation Preparation

1. Engage parking brake.
2. Turn key OFF.
3. Electric Carts Only: Place Tow/Run Switch in Tow.
4. Remove top.

NOTE: If reinstalling the top, keep the top attached to the front struts and prop up the rear of the top using a broom handle or similar tool. Retain hardware.

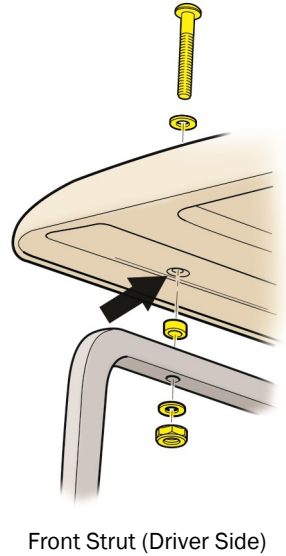
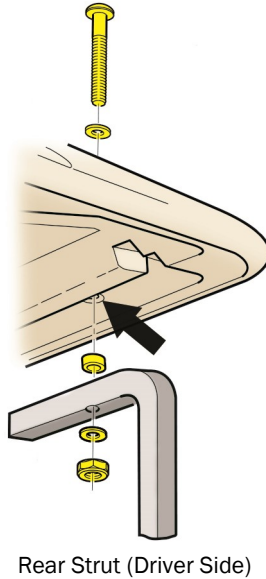

5. Remove the front seat back cushion (black arrows). Retain hardware.
6. Remove rear struts (red arrows). Retain hardware.

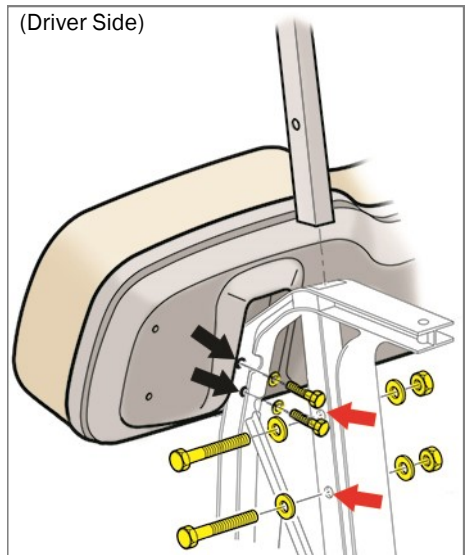

7. Remove both seat back supports and the bag attachment. Driver side seat support shown.

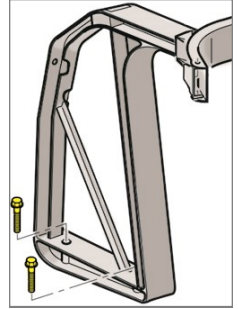

Rear Seat Kit Installation

1. Install the new front seat back support brackets where the original bracket was installed using (4) 3/8-16 x 1.5" Hex Head Bolts and (4) 3/8" Flat Washers.

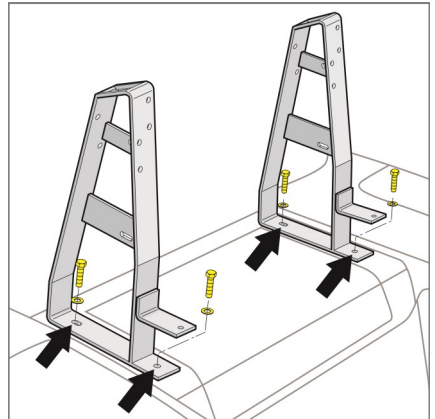

2. Loosely fasten the vertical support bracket to the bagwell area using (2) 8mm x 45 Hex Head Bolts, (4) Flat Washers and (2) Nylock Nuts.

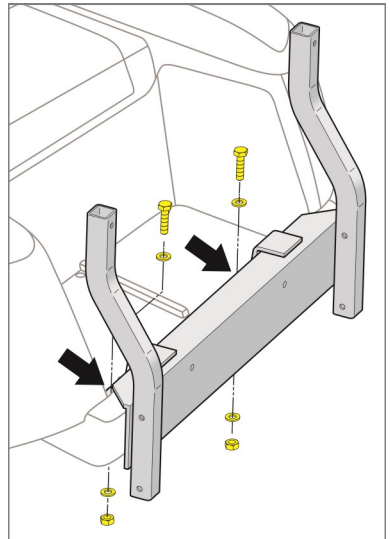

3. Insert the (4) M6 Square Nuts into the lower portions of the arm rests.

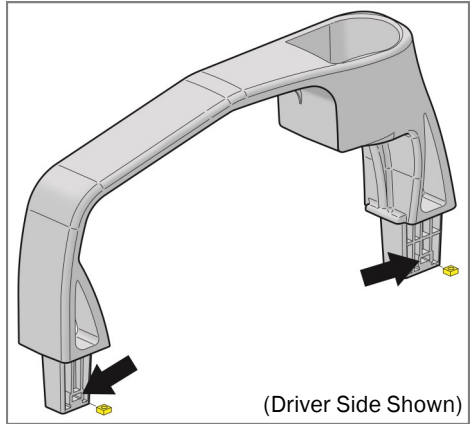
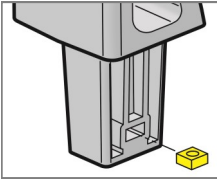

4. Place the arm rests with the square nuts inside of the seat platform as shown. Fasten the arm rests to the platform using (2) M6 x 70 Hex Head Bolts (black arrow), (2) M6 x 45 Hex Head Bolts (red arrow) and (4) M6 Flat Washers. **Fully tighten with hand tools but do not overtighten. Overtightening will cause damage.**

NOTE: Driver side and passenger side arm rests are different. If oriented correctly, the slots for the square nuts will face the outside of the platform.

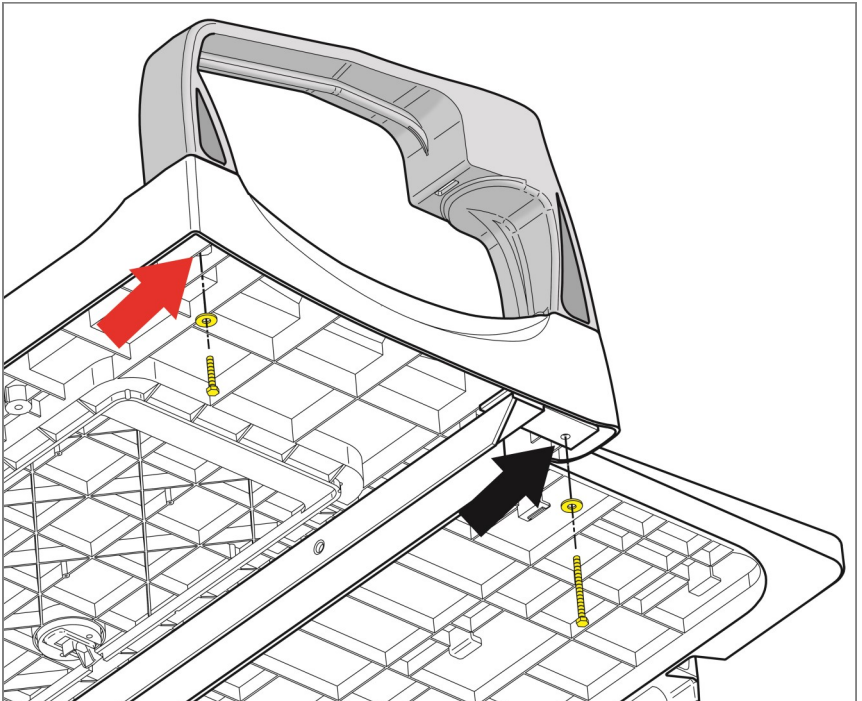

5. Place the platform sub-assembly on top of the seat back support brackets and vertical support bracket. A second installer will be helpful on this step.
6. Loosely fasten the platform to the seat back supports using (2) M6 x 30 Hex Head Bolts, (4) M6 Flat Washers and (2) M6 Nylock Nuts (black arrows).
7. Loosely fasten the platform to the vertical support bracket using (2) M8 x 55 Hex Head Bolts, (4) M8 Flat Washers and (2) M8 Nylock Nuts (red arrows).

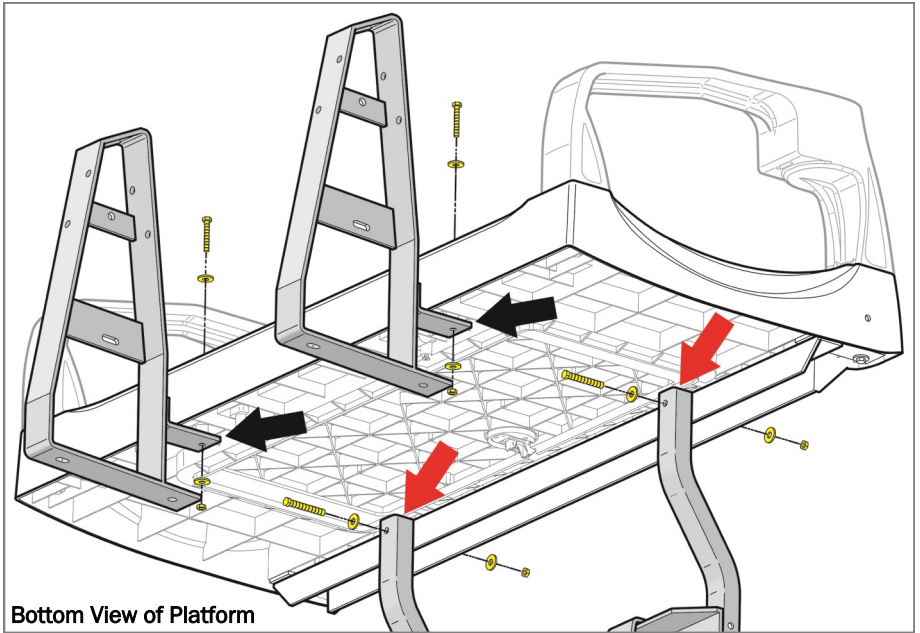

8. Loosely fasten the footplate to the vertical support bracket using (2) M8 x 55 Hex Head Bolts, (4) M8 Flat Washers and (2) M8 Nylock Nuts (upper mounting holes).
9. Secure the footplate to the bottom of the vertical support bracket using (2) Clevis Pins and (2) Cotter Pins (not shown).

STORAGE NOTE:

To save space once assembled, the clevis and cotter pins can be removed to fold the footplate assembly towards the cart.

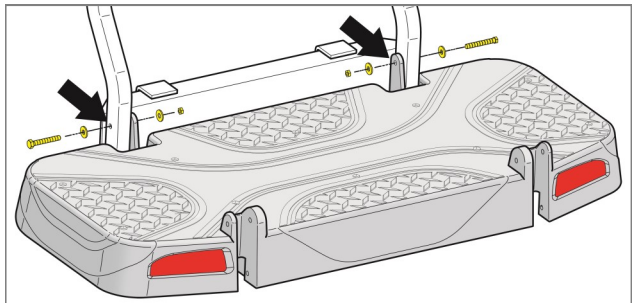

10. Secure the safety grab bar to the footplate using (2) Clevis Pins and (2) Cotter Pins on the upper mounting holes (black arrows) and (2) M6 x 35 Hex Head Bolts and (2) M6 Flat Washers on the lower mounting holes (red arrows).

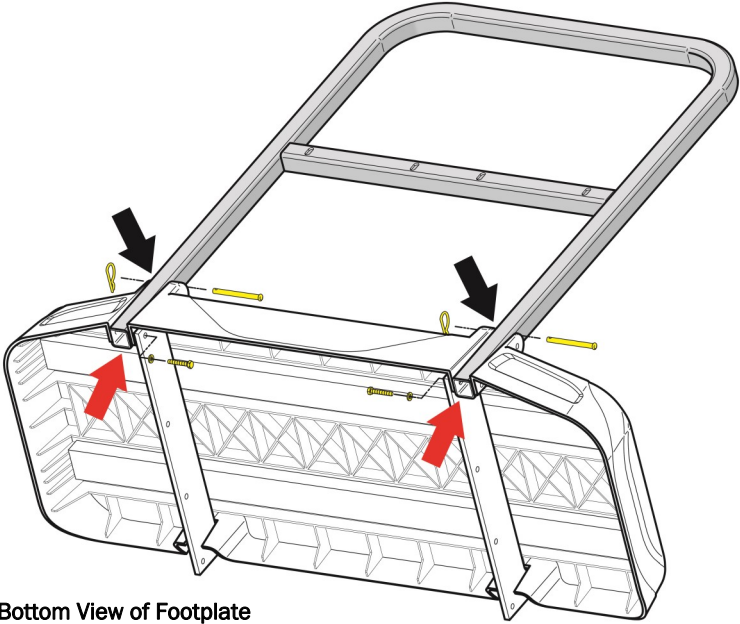

Bottom View of Footplate

11. Install the front seat back to the new seat back brackets using the Original Hardware.
12. Loosely fasten the rear seat back cushion to the rear seat back brackets using (4) M6 x 30 Hex Head Bolts, (4) M6 Lock Washers and (4) M6 Flat Washers. Hand tighten.

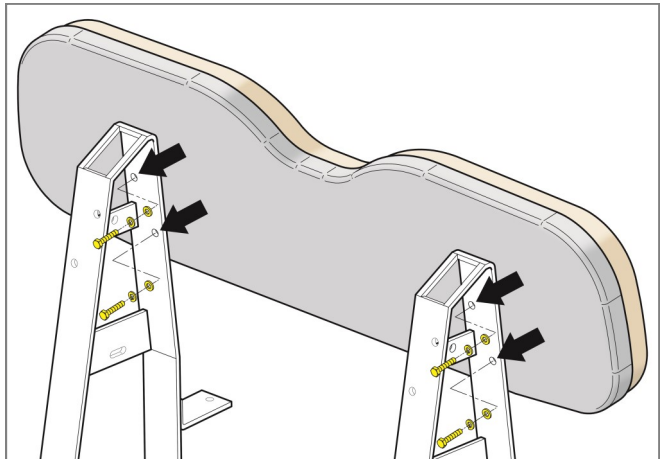

13. If reinstalling the OE top and struts, install them to the seat back supports using the Original Hardware.

NOTE: RHOX 88" Tops require TOP-0511 rear struts. Install TOP-0511 rear struts in the same location as the OE struts.

14. Optional Weather Seal: Clean the surface of the platform indicated by the red dashed line. Adhere the weather seal to the platform following the red dashed line.
15. Align the recessed areas on the seat bottom cushion with the locking tabs on the seat platform (yellow). Slide the seat bottom onto the platform until it locks into place on the locking tabs.

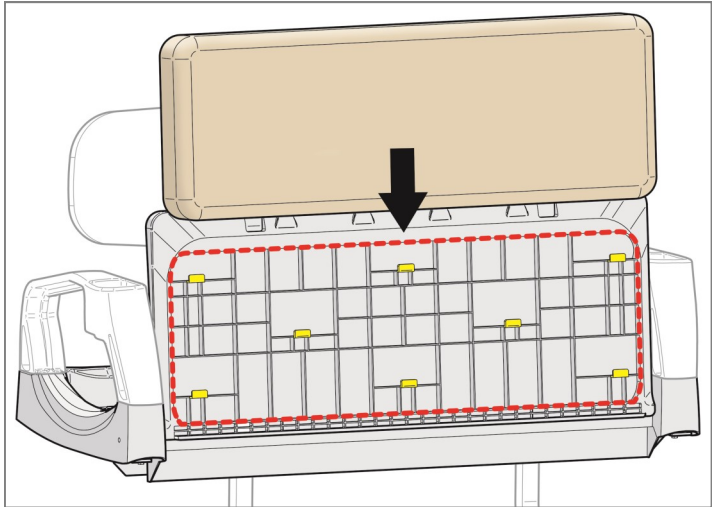

16. Secure the seat bottom using (1) seat bottom handle and (2) No. 10 x 3/4" Flat Head Sheet Metal Screws. Hand tighten.

17. Tighten any hardware left loose in this installation.

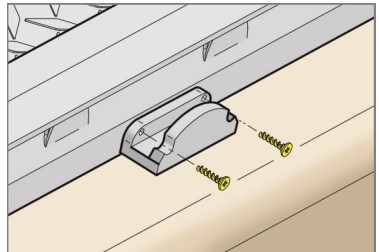

This completes the installation of your RHOX 500 Series Rear Seat Kit. Please enjoy safely!

Scan QR code or use the link below to view our installation video library.

<https://www.youtube.com/user/golfcartinstructions>

